

---

# Clarke<sup>®</sup>

---

# American Sanders

**Operator's  
Manual**

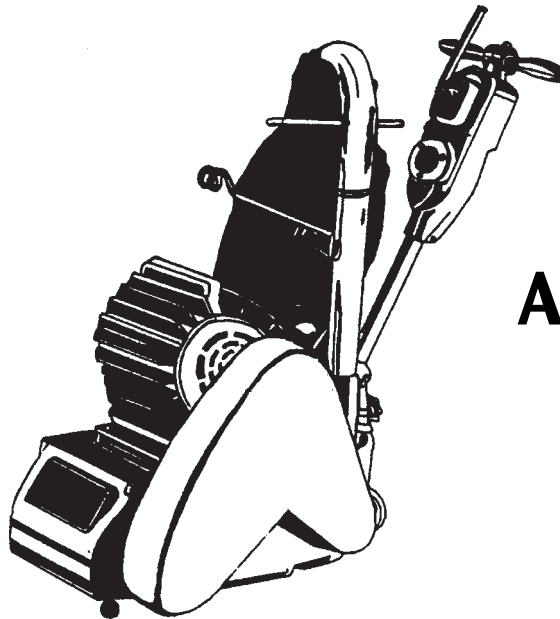

**American 8**

## **READ THIS BOOK**

This book has important information for the use and safe operation of this machine. Failure to read this book prior to operating or attempting any service or maintenance procedure to your Clarke American Sanders machine could result in injury to you or to other personnel; damage to the machine or to other property could occur as well. You must have training in the operation of this machine before using it. If your operator cannot read this manual, have it explained fully before attempting to operate this machine.

Si Ud. o sus operadores no pueden leer el Inglés, se hagan explicar este manual completamente antes de tratar el manejo o servicio de esta máquina.

All directions given in this book are as seen from the operator's position at the rear of the machine.

For new books write to: Clarke<sup>®</sup>, 2100 Highway 265, Springdale, Arkansas 72764

## Contents of this Book

Operator Safety Instructions .....	3
Introduction and Machine Specifications .....	5
230V Electrical Connection Instructions .....	6
How to Transport the Machine .....	7
Machine Set-Up .....	8
How to Operate the Machine .....	10
Sanding Cuts and Sandpaper .....	13
Sander Adjustment Procedures .....	14
Routine Maintenance .....	16
Troubleshooting .....	17
Wiring Diagram .....	19
Assembly Drawing #1 .....	20
Assembly Parts List #1 .....	21
Assembly Drawing #2 .....	22
Assembly Parts List #2 .....	23
Assembly Drawing #3 .....	24
Assembly Parts List #3 .....	25
Accessories Drawing & Parts List .....	26
Chatter-Wave Prevention .....	27

# OPERATOR SAFETY INSTRUCTIONS



**WARNING**



**AVERTISSEMENT**



**ADVERTENCIA**

<b>DANGER</b> means:	Severe bodily injury or death can occur to you or other personnel if the <b>DANGER</b> statements found on this machine or in this Owner's Manual are ignored or are not adhered to. Read and observe all <b>DANGER</b> statements found in this Owner's Manual and on your machine.
<b>WARNING</b> means:	Injury can occur to you or to other personnel if the <b>WARNING</b> statements found on your machine or in this Owner's Manual are ignored or are not adhered to. Read and observe all <b>WARNING</b> statements found in this Owner's Manual and on your machine.
<b>CAUTION</b> means:	Damage can occur to the machine or to other property if the <b>CAUTION</b> statements found on your machine or in this Owner's Manual are ignored or are not adhered to. Read and observe all <b>CAUTION</b> statements found in this Owner's Manual and on your machine.



**DANGER:**

Failure to read the Owner's Manual prior to operating or attempting any service or maintenance procedure to your Clarke American Sanders machine could result in injury to you or to other personnel; damage to the machine or to other property could occur as well. You must have training in the operation of this machine before using it. **If you cannot read English, have this manual explained fully before attempting to operate this machine.**



**DANGER:**

















Sanding/finishing wood floors can create an environment that can be explosive. The following safety procedures must be adhered to:

- Cigarette lighters, pilot lights and any other source of ignition can create an explosion when active during a sanding session. All sources of ignition should be extinguished or removed entirely if possible from the work area.
- Work areas that are poorly ventilated can create an explosive environment when certain combustible materials are in the atmosphere, i.e., solvents, thinners, alcohol, fuels, certain finishes, wood dust and other combustible materials. Floor sanding machines can cause flammable material and vapors to burn. Read the manufacturer's label on all chemicals used to determine combustibility. Keep the work area well ventilated.
- Spontaneous combustion or an explosion can occur when working with sanding dust. The sanding dust can ignite and cause injury or damage. Sanding dust should be disposed of properly. Always empty the sanding dust into a metal container that is located outside of any building(s).
- Remove the contents of the dust bag when the bag is 1/3 full. Remove the contents of the dust bag each time you finish using the machine. Never leave a dust bag unattended with sanding dust in it.
- Do not empty the contents of the dust bag into a fire.
- Hitting a nail while sanding can cause sparks and create an explosion or fire. Always use a hammer and punch to countersink all nails before sanding floors.



**DANGER:**

Operating a machine that is not completely or fully assembled could result in injury or property damage. Do not operate this machine until it is completely assembled. Keep all fasteners tight. Keep adjustments according to machine specifications.

-  **DANGER:** Electrocutation could occur if the machine is used on a power circuit that repeatedly trips or is undersized. Have a licensed electrician check the fuse, circuit breaker or power supply.
-  **DANGER:** Electrocutation could occur if maintenance and repairs are performed on a unit that is not properly disconnected from the power source. Disconnect the power supply before attempting any maintenance or service.
-  **DANGER:** Electrocutation could occur if machine is used on ungrounded electrical circuit. Never remove or disable the grounding supply conductor on the electrical cord. Consult an electrician if the grounding conductor is missing or if you suspect your circuit is not grounded properly.
-  **DANGER:** Use of this machine with a damaged power cord could result in an electrical shock. Do not use the machine if the power cord is damaged. Do not use the electrical cord to move the machine.
-  **DANGER:** Electrocutation or injury could occur if the power cord is run over or damaged by the sander. Keep the cord free from under the machine to avoid contact with the sandpaper. Always lift the power cord over the machine.
-  **DANGER:** Moving parts of this machine can cause serious injury and/or damage. Keep hands, feet and loose clothing away from all moving parts of the sander.
-  **DANGER:** Operating a sander without all guards, doors or covers in place can cause an injury or damage. Always check to make sure that all of the guards, doors and covers are secure and in place.
-  **DANGER:** Injury to the operator or bystanders could occur if the power supply remains connected when servicing the equipment, changing abrasive, or emptying the dust bag.
-  **WARNING:** Failure to read and observe all safety statements found on your machine or in this Owner's Manual can result in serious injury or damage. Read and observe all safety statements. Make sure that all labels, decals, warnings, cautions, and instructions are fastened to the machine. Get new labels from your authorized Clarke American Sanders distributor.
-  **WARNING:** Sanding dust can be airborne and can be breathed in while operating a sander. Always wear a dust mask while operating sanding equipment.
-  **WARNING:** Injury to the eyes and/or body can occur if protective clothing and/or equipment is not worn while sanding. Always wear safety goggles, protective clothing, and a dust mask while performing any sanding operation.
-  **WARNING:** Bodily injury could occur if power is applied to the machine with the power switch already in the "ON" position. Always check to assure that the power switch is in the "OFF" position before applying power to the power cable.
-  **CAUTION:** Maintenance and repairs performed by unauthorized personnel could result in damage or injury. Maintenance and repairs performed by unauthorized personnel will void your warranty. Servicing of this unit must always be referred to an authorized Clarke American Sanders distributor.
-  **CAUTION:** Use of this machine to move other objects or to climb on could result in injury or damage. Do not use this machine as a step or furniture. Do not ride on this machine.
-  **CAUTION:** Damage could occur to the machine if not properly kept in a dry building for storage. Store the machine in a dry building.
-  **CAUTION:** The machine is heavy. When transporting the machine, remove the motor. Get help to lift the machine and motor.
-  **CAUTION:** Serious damage to the floor can occur if the machine is left running in one spot while the sanding drum is in contact with the floor. To avoid damage to the floor, feather cut in at a normal sanding rate. Do not dwell while lowering or raising the contact wheel. Always sand at a constant rate.

## Introduction and Machine Specifications

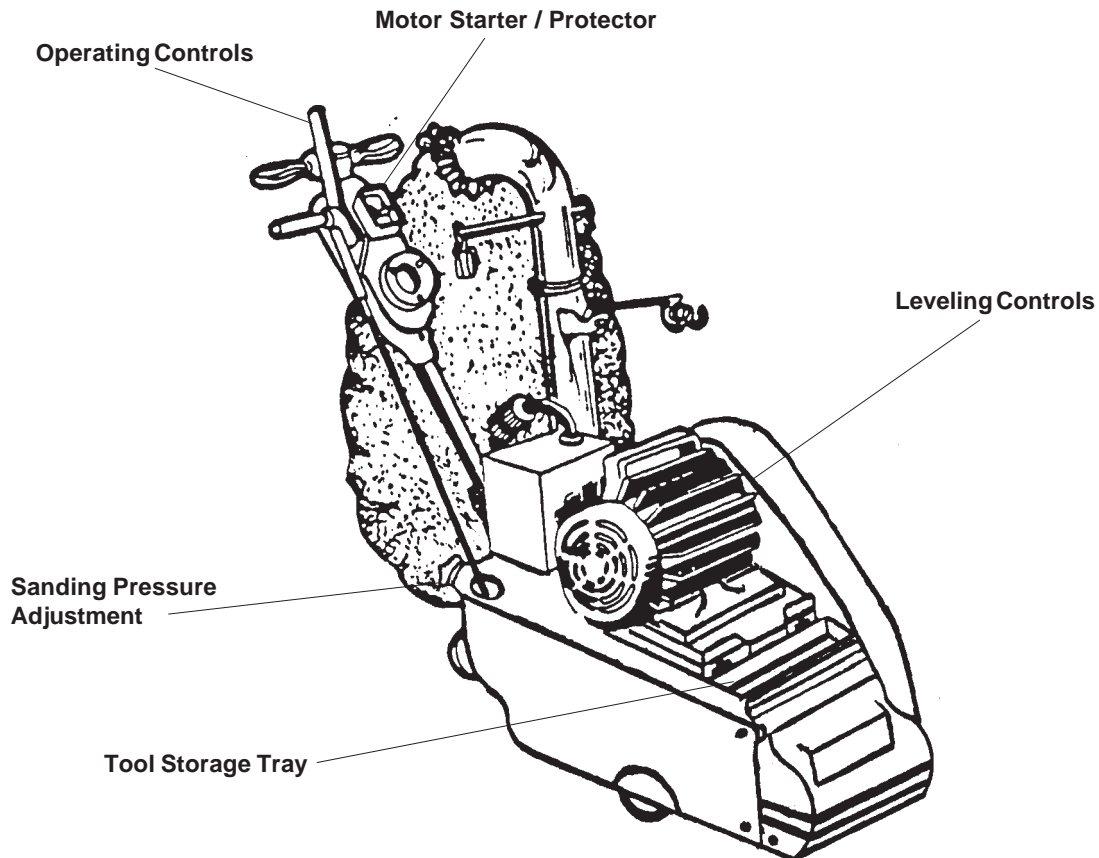

PART NUMBER	07032C	07105A	07048C	07106A
Abrasive Size	8 x 26½" paperback		20.3 x 67.3 cm	
Contact Wheel Speed (rpm)*	2400/2800		2000/2333	
Abrasive Speed (sfm)* (m/min)*	4398/5131 sfm		1117/1303 m/min.	
Dust Fan Speed (rpm)*	6000		5000	
Dust Fan Flow (cfm)*	210 cfm		83 liters/second	
Motor	60 Hz 230V 4hp (3 kW)		50 Hz 240V 3hp (2.2 kW)	
Leveling Control	Externally Adjustable			
Operating Control	Adjustable Lever			
Motor Starter/Protector	Magnetic Circuit Breaker			
Sanding Pressure Adjustment	Infinitely Adjustable			
Wheels (Truck Assembly)	Steel **	Urethane***	Steel**	Urethane***
Wheel (Rear)	Steel	Canvas	Steel	Canvas
Drive	V-Belt			
Dimensions	40½ x 15 x 36 ¾		103 cm x 38 cm x 93 cm	
Weight	216 lbs.		98kg	

\* revolutions per min.      \*surface feet per min.      \*meters per min      \* cubic feet per min.  
 \*\*Steel (Standard) Urethane or canvas (optional)      \*\*\*Urethane (Standard) Steel or Canvas (optional)

**⚠ CAUTION:** Your equipment may be inappropriate on some installations. Some softer woods used in flooring cannot support the pressure created by hard wheels. A felt or rubber wheel should be used when these woods are encountered. See parts list for optional wheels.

Always consult with the flooring manufacturer on the proper installation, preparation, and finishing of their product. Determine suitability of your equipment in preparing the product.

## 230V Electrical Connection Instructions

**CAUTION:** This machine will operate only on AC frequency and on electrical voltage shown on the motor nameplate. Make sure you have the correct frequency and voltage before connecting the power cord to an outlet. The machine has a plug as shown below.

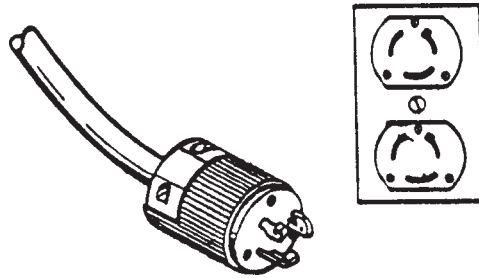

This machine must be connected to an electrically ground circuit in order to protect the operator from electric shock. This machine has an approved power cord with three conductors as well as a plug with three terminals. Connect the plug into a three holed receptacle. For maximum protection against electric shock, use a circuit that is protected by a ground fault circuit interrupter.

**DANGER:** Electrocutation could occur if the machine is exposed to water or rain. Keep the machine in a dry building.

**DANGER:** Electrocutation could occur if machine is improperly connected to the electrical system. To prevent possible electric shock, always use a 3-wire electrical system connected to an electrical ground. For maximum protection against electrical shock, use a circuit that is protected by a ground fault circuit interrupter. Consult your electrical contractor.

**DANGER:** Electrocutation could occur if the ground pin is tampered with in any way. Do not cut, remove, or break the ground pin. Do not try to fit a three-terminal plug into a receptacle or connector body other than a three plug receptacle or connector body. If the outlet does not fit the plug, consult your electrical contractor.

**DANGER:** Electrocutation could occur if the machine is used with a damaged plug or power cord. If the cords or plugs are worn or damaged in any way, have them replaced by an authorized service person or electrician.

### Extension Cords

Use only an approved three-pronged extension cord with two main conductors and one earthing conductor. This machine's power cord has a wire size of 10 gauge. This machine is equipped with a 100' power cord. When greater range is needed follow the table below to determine cable gauge of additional footage. Refer to the following chart for extension cord information.

Feet/Wire Gauge (Stranded Copper)

Source Voltage	0 - 100'	100 - 250'
208	6	Use Voltage Booster
230	10	8

If motor appears to labor or takes a considerable longer time to come up to speed reduce sanding pressure.

## How to Transport the Machine

**⚠ WARNING:** The machine is heavy. Remove the motor from the machine before transporting. Get help loading the machine and motor.

To transport the machine, follow this procedure:

1. Make sure the power cable is disconnected from the electrical outlet.
2. Disconnect the handle plug connection. See figure 1.
3. Remove the belt cover.
4. Remove the fan belt.
5. Loosen the motor bolt. Using the  $\frac{3}{4}$ " wrench, turn the motor bolt counterclockwise.
6. Using the  $\frac{9}{16}$ " wrench, remove the two hex nuts (1).
7. Lower the motor locating screws (2). To lower the motor locating screws, turn the screws clockwise. Make sure the screws are aligned with the openings at the front of the motor platform. See figure 2.
8. Slide the motor forward.
9. Remove the drive belt.
10. Remove the motor from the chassis.

**To re-assemble the machine after transporting, follow this procedure:**

1. Reposition motor on chassis.
2. Install the drum belt. Slide the motor back until adequate tension is achieved in belt.

**⚠ CAUTION:** To prevent damage to the floor surface, make sure the drive belt is tight.

3. Resecure the motor to the chassis.
4. Install the fan belt.
5. Install the belt cover.
6. Reconnect the handle plug.

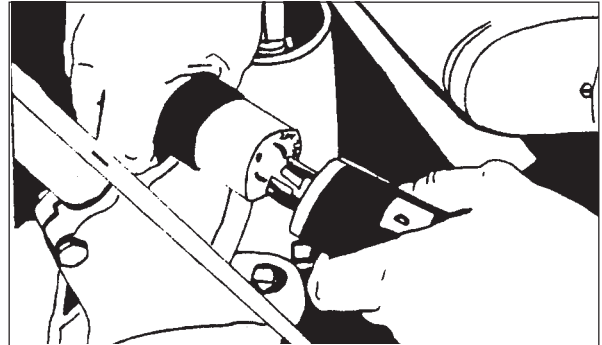

Figure 1

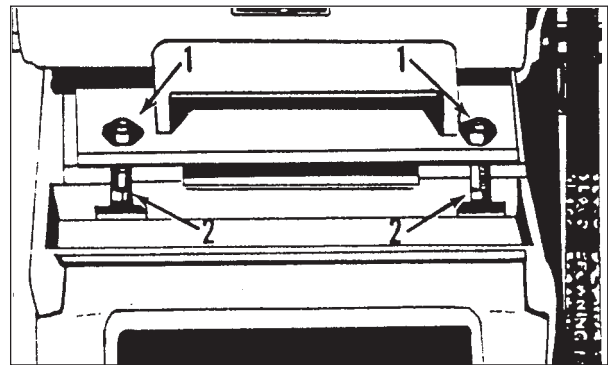



Figure 2

## Machine Set-Up

To set-up your machine follow this procedure:

1. Familiarize yourself with the machine and read all danger, warning and caution statements. Make sure all operators of this machine have read this Owner's Manual. If they cannot read English, have the manual explained fully before allowing anyone to operate the sander.
2. Locate the power supply. The receptacle should be compatible with the plug. The receptacle must be grounded and must be fused (30 amp) to avoid an electrical hazard.
3. Clip the dust bag to the elbow. Cross the strings on the dust bag and draw tight over the flare on the elbow. Wrap the string around the elbow and secure.
4. Wind the power cord through the cable arm. Keep the power cord out of path of equipment.

### How To Install The Abrasive

 **WARNING: Disconnect power before changing abrasive.**

To install the abrasive, follow this procedure:

1. Prepare abrasive with template supplied.
2. Place backing of abrasive on the template. The template is marked "This Side Up." Make sure the marked side of the template is facing up.
3. Cut the abrasive to the exact length of the template.
4. Align one edge of the abrasive with a notch in the template.
5. Fold the other end of the abrasive over the end of the template and crease.
6. Repeat steps 4 and 5 for remaining notch.
7. Lift the drum cover.



8. Put the smooth side of the abrasive against the sanding drum.
9. Put one end of the abrasive against the sanding drum slot (1). See figure 3.
10. Turn the drum one revolution. Put the other end of the abrasive in the drum slot (2). See figure 3.
11. Tighten the abrasive.

To tighten the abrasive, follow this procedure:

1. The end wrenches are given with the machine. Put a wrench around the nut at each end of the drum (1). See figure 4.
2. Make sure the flat sides of the nuts are parallel with the drum slot.
3. Turn the wrenches the opposite rotation until the abrasive is tight against the drum (2). See figure 4.

12. Remove the end wrenches.
13. Close the cover.

**NOTE:** When using #4 or 4½ grit abrasive, remove the large grains from the folded ends. To remove the grains, rub the folded ends together.

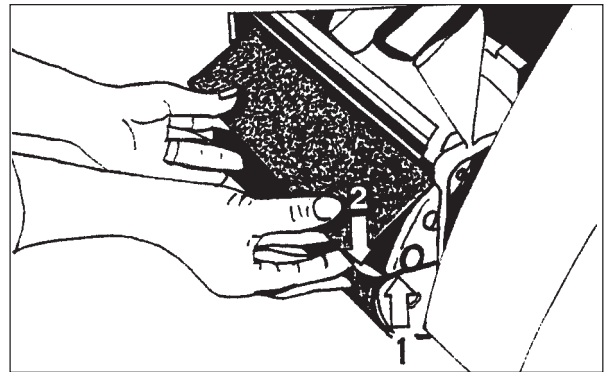

Figure 3

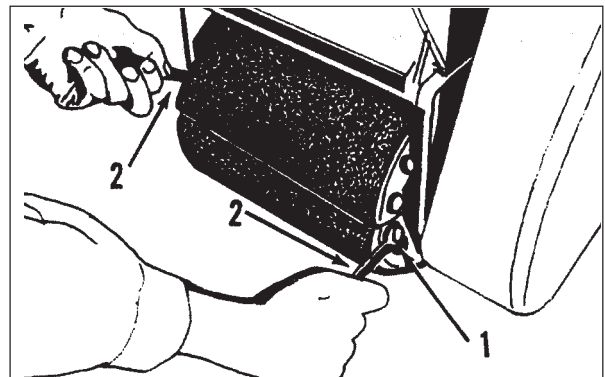





Figure 4

## How to Operate the Machine

 **DANGER:** Sanding/finishing wood floors can create an environment that can be explosive. Cigarette lighters, pilot lights and any other source of ignition can create an explosion when active during a sanding session. All sources of ignition should be extinguished or removed entirely if possible from the work area.

 **DANGER:** Work areas that are poorly ventilated can create an explosive environment when certain combustible materials are in the atmosphere, i.e., solvents, thinners, alcohol, fuels, certain finishes, wood dust and other combustible materials. Floor sanding machines can cause flammable material and vapors to ignite. Read the manufacturer's label on all chemicals used to determine combustibility. Keep the work area well ventilated.

 **DANGER:** Sanding dust can spontaneously ignite and cause an injury or damage. Sanding dust should be disposed of properly. Always empty the sanding dust into a metal container. Remove the contents of the dust bag when the bag is 1/3 full.

 **DANGER:** Sanding dust can spontaneously ignite and cause an injury or damage. Remove the contents of the dust bag each time you finish using the machine. Always dispose of the dust in a metal container located outside of the building. Never leave a dust bag unattended with sanding dust in it. Do not empty the contents of the dust bag into a fire.

 **DANGER:** Hitting a nail while sanding can cause sparks and create an explosion or fire. Always use a hammer and punch to countersink all nails before sanding floors.

To operate the machine follow this procedure:

1. Install the operator's belt as follows:
  - a. Position the operator's belt around waist.
  - b. Cross the straps at the waist. See figure 5.
  - c. Slide the belt loop end over the handle on the control lever side. Adjust the length as needed.
  - d. Wrap the remaining strap around the opposite side of the handle and hold it in place with your hand.

**⚠ WARNING:** **Should quick release of the machine be necessary, serious operator injury could occur if the operator has tied the loose end of the operator's belt strap to the machine. Always position the strap so that you can let go and get away quick in case of bag fire or explosion.**

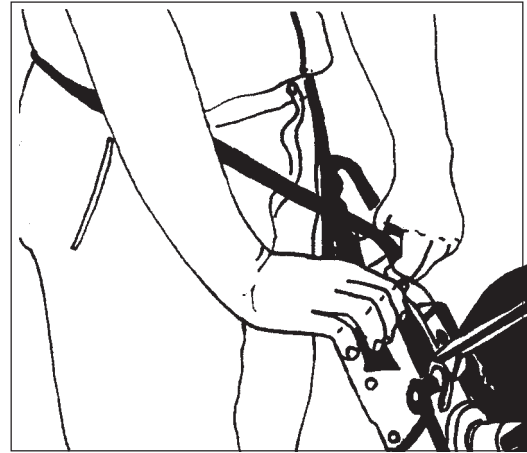
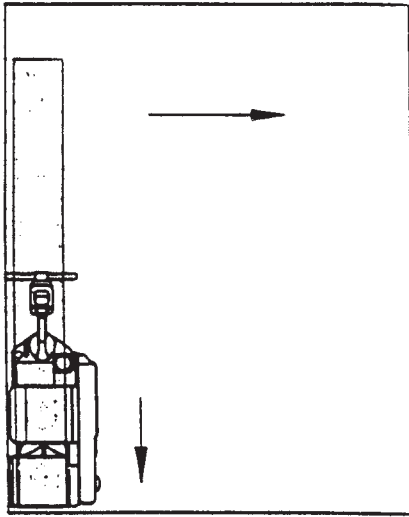

Figure 5

2. Put the On/Off switch into the "ON" position.

**⚠ DANGER:** **Serious damage can occur to the floor surface if the machine is not in motion while the contact wheel is running on the floor surface. To prevent damage to the surface, make sure the machine is always moving when the contact wheel is in contact with the floor.**

3. Work right to left. For each forward pass, move the machine 4" over the pass you have just finished. Retrace your reverse path without overlapping. See figure 6.
4. Feather-cut in by easing the contact wheel down onto the surface with the control lever while the sander is in motion.
5. When contact wheel is fully engaged with the surface, gradually adjust your pace for adequate finish removal. Keep sander in motion while the contact wheel is engaged with the surface or dwell marks will occur.
6. Move the machine in the direction of the grain in the wood whenever it is possible. Sand the surface at a constant pace.
7. Gradually feather-cut out at the termination point (the end of your pass) by easing the contact wheel up with the control lever. Stagger the termination points for a better blend when edging.
8. Empty dust bag whenever it is 1/3 full. Never leave a dust bag unattended with sanding dust in it. Sanding dust can spontaneously ignite and cause a fire or explosion. Empty dust into a metal container located **outside of the building**.



A. First pass forward, right to left.

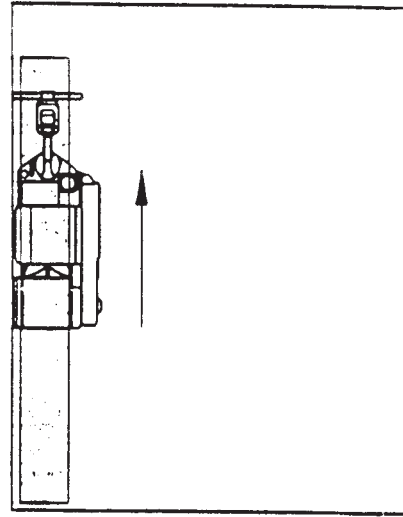

B. First pass reverse, retrace same path.

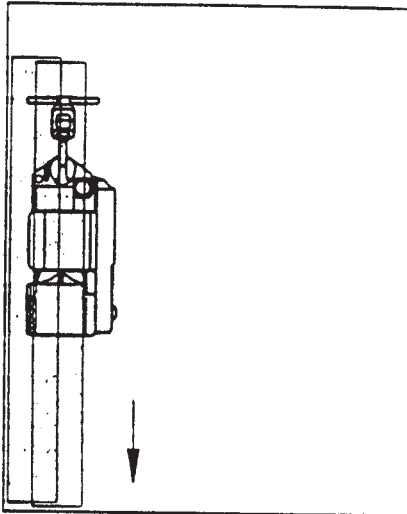

C. Second pass forward, overlap  $\frac{1}{2}$  the drum width.

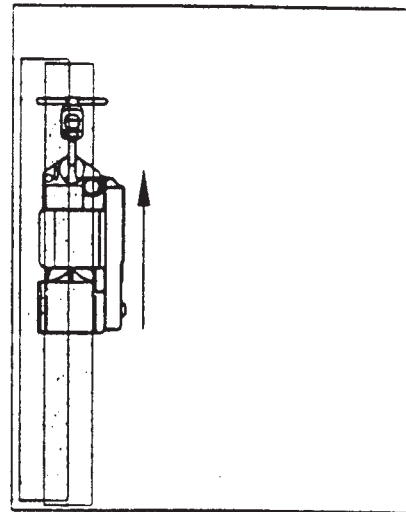

D. Second pass reverse, retrace second path forward, etc.....for the entire room.

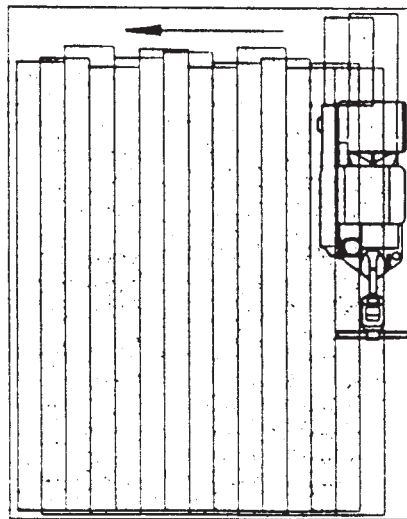

E. Work the remaining unsanded floor in the same fashion, right to left.

**Figure 6**

## Sanding Cuts and Sandpaper

### Initial Cut

The purpose of the initial cut is to remove old finish and gross imperfections on the floor surface. The sanding equipment should be adjusted to heavy sanding pressure setting and a coarse abrasive should be used. If the surface is severely damaged by deep scratches, pre-existing dwell marks, uneven planks, etc., it may be necessary to sand across or diagonally to the grain to restore evenness to the surface. If these conditions are not present, the initial cut should be done in the direction of the grain.

If glazing, loading, or burning takes place immediately into an initial cut, select a coarser abrasive. If this should occur during an initial cut, the abrasive has dulled and must be replaced.

### Final Cuts

The purpose of a finishing cut is to remove the scratches produced during the initial cut. Use a fine (60 - 80 grit) grain abrasive and a reduced sanding pressure setting.

If the surface remains rough after a finishing cut, it may be necessary to use an even finer grain of abrasive (80 - 100 grit). Care should be taken in selecting the grit size of the abrasive. A very fine grain will close the pores on a wood floor making admission of a stain difficult.

If glazing or burning should occur immediately into a finishing cut, reduce the sanding pressure. If it should occur during a finishing cut, the abrasive has dulled and must be replaced.

Abrasive Bulk Roll		
Note: All part numbers listed are for 8" x 50' (203cm x 15m)		
Grain	Use	Part No.
12 grit 16 grit 20 grit 24 grit	For removing gross imperfections and restore evenness to old flooring. To remove build-up of paints and varnishes.	945500 945501 945502 945503
30 grit 36 grit	For first sanding of new flooring (maple, oak). For removing minor imperfections and finishes from old flooring.	945504 945505
40 grit	For first sanding of new flooring (oak, walnut). For removing minor imperfections and finishes from old flooring.	945506
50 grit	For first sanding of new flooring (cedar, pine, fir) For clean-up of 16 grit.	945507
60 grit	For clean-up from initial cut 36 - 40 grit.	945508
80 grit	For final sanding of certain hardwoods. For clean-up of initial cuts (50 grit).	945509
100 grit	For final sanding of certain hardwoods where a smooth surface is desired.	945510
120 grit	For final sanding of certain conifers.	945511
150 grit	For final sanding of certain conifers where a smooth surface is desired.	945512

## Sander Adjustment Procedures

 **DANGER:** Electrocution could occur if maintenance and repairs are performed on a unit that is not properly disconnected from the power source. Disconnect the power supply before attempting any maintenance or service.

 **DANGER:** Moving parts of this machine can cause serious injury and/or damage. Keep hands, feet and loose clothing away from all moving parts of the sander.

### Sanding Pressure

To adjust the sanding pressure follow this procedure:

1. Screw the sanding pressure knob down to increase the sanding pressure when making the roughing in cut.
2. Screw the sanding pressure knob up to decrease the sanding pressure when making the finishing cut.

### Drum Rates

The machine can be operated at two rates. To change the speed of the drum, follow this procedure:

1. Remove the belt cover.
2. Remove the fan belt.
3. Loosen the motor bolt.
4. Remove the hex nuts at the front of the motor.
5. Using the 5/32" Allen wrench, lower the motor locating screws.
6. Slide the motor forward.
7. For high drum rates, install drive belt in larger diameter of the grooves available on the motor pulley and in the smaller diameter of the two grooves available on the drum pulley. For lower rates, install drive belt in smaller diameter of the grooves available on the motor pulley and in the larger diameter of the two grooves available on the drum pulley.
8. Tighten belt and secure motor to chassis.
9. Install the fan belt.
10. Install the belt guard.

## **Leveling**

If the sanding drum is out of adjustment, follow this procedure:

1. Remove the belt cover.
2. Loosen the eccentric lock screw. Using the 7/16" wrench, turn the eccentric lock screw (1) counter-clockwise. See figure 7.
3. To raise or lower the drum, turn the eccentric (2). See figure 7.
4. Tighten the eccentric lock screw. To tighten the eccentric lock screw, turn the screw clockwise.
5. Install the belt cover.

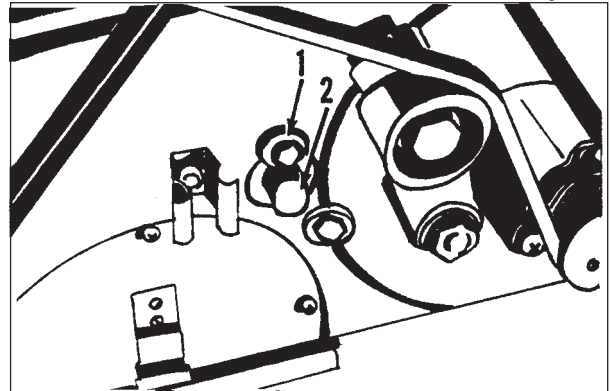

Figure 7

## **How to Lubricate the Wheel Pivots**

**NOTE: The wheel pivots must be lubricated after every 25 hours of use.**

To lubricate the wheel pivots, follow this procedure:

1. Put the machine on its side.
2. Lubricate the pivots. The pivots are behind the truck wheels. See figure 8.
3. Put the machine on its wheels.

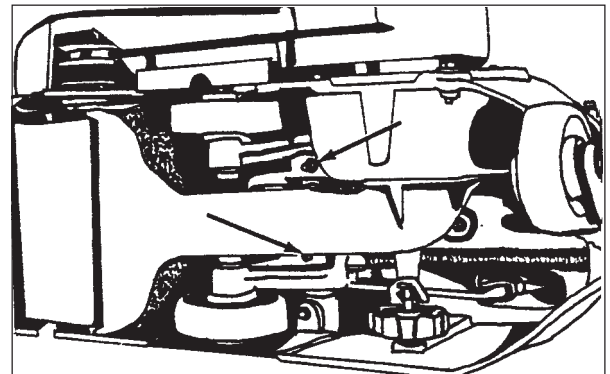

Figure 8

## **Operating Control**

To **increase** the travel or extend the reach on the grip control follow this procedure:

1. Loosen the locknut on the control rod. See figure 9.
2. Screw the control rod adjuster **in** until the desired reach is found.
3. Tighten the locknut.

To **decrease** the travel or reduce the reach on the grip control follow this procedure:

1. Loosen the locknut on the control rod. See figure 9.
2. Screw the control rod adjuster **out** until desired reach is found.
3. Tighten the locknut.

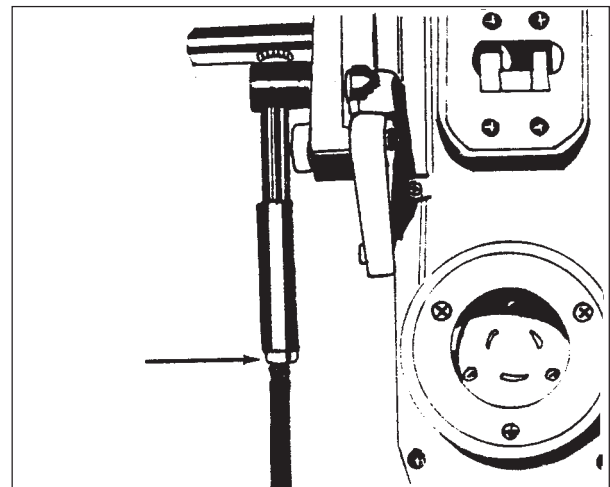

Figure 9

---

## **Routine Maintenance**

The following items need to be periodically inspected and maintained to keep your sander in good working condition.

### **Wheels**

Periodically remove the debris from the truck and caster wheels. Debris can cause waves on a sanded surface. Lubricate truck mechanism every 25 hours of use. The machine is equipped with lubrication fittings and are located on shaft supporting mechanism.

### **Dust Bag**

Remove the dust bag from the machine and shake it thoroughly to remove the sanding dust from the dust bag. Turn the dust bag inside out and machine wash in cold water to prevent pore blockage and loss of dust recovery.

### **Drive Belt**

Periodically check the drive belt tension.

### **Bearings**

Periodically check the bearings for wear or damage according to the following schedule:

<i>Idler pulley</i>	after 1st 1500 hrs.
<i>Fan shaft</i>	after 1st 2500 hrs.
<i>Arbor shaft</i>	after 1st 5000 hrs.
<i>Motor shaft</i>	after 1st 5000 hrs.



## Troubleshooting

PROBLEM	CAUSE	ACTION
<b>Drive belts slip.</b> (Squeaking or squealing sound)	Insufficient tension. Worn belts.	Tension drive belts Replace belts.
<b>Squealing, growling or grinding noise coming from machine.</b>	Damaged and/or worn bearing.	Remove drive belts, rotate arbor motor, fan, shafts and idler pulley to locate dragging or rough bearing. Contact an authorized dealer.
<b>Dust pick-up is poor.</b> Dust chute is obstructed.	Dust bag is over 1/3 full. Dust bag is dirty. Remove fan cover and clear throat.	Empty contents of bag. Shake debris from bag and wash.
<b>Motor will not start.</b>	Defective motor starter. Defective start capacitor. Defective electronic start switch. Defective motor. No power.	Contact an authorized dealer. Contact an authorized dealer. Contact an authorized dealer. Contact an authorized dealer. Check power supply and connections.
<b>Motor runs sluggishly.</b>	Low voltage from excessive footage, undersized extension cord, or poor connection.  Defective run capacitor.  Defective motor.	Locate power source nearer to work site. Decrease sanding pressure.  Contact an authorized dealer.  Contact an authorized dealer.
<b>Motor starter trips/repeatedly trips.</b>	Excessive load. Defective electronic start switch. Defective motor starter. Low voltage from poor connection. Defective motor Defective capacitor.	Contact an authorized dealer. Contact an authorized dealer. Contact an authorized dealer. Contact an authorized dealer. Contact an authorized dealer. Contact an authorized dealer.
<b>Uneven cut.</b>	Leveling out of adjustment.	Readjust leveling.
<b>Burning or glazing.</b>	Dull abrasive. Excessive sanding pressure. Too fine of an abrasive.	Replace abrasive. Decrease sanding pressure setting. Use coarser abrasive.
<b>Slow cutting.</b>	Dull abrasive. Too fine of an abrasive. Insufficient sanding pressure.	Replace abrasive. Use a coarser abrasive. Increase sanding pressure setting.
<b>Waves on sanded surface.</b>	Debris on wheel. Flat spot on tire(s).	Remove and clean wheels. Replace tires.
<b>Chatter marks on sanded</b>	Drum out of round. surface (close evenly spaced ) Drum vibration. from surface or ends of drum.	Contact an authorized dealer. or replace the drum. Change shim combination. Remove debris



**Clarke®**  
**American Sanders**  
 American Sander 8  
 Wiring Diagram 4/93

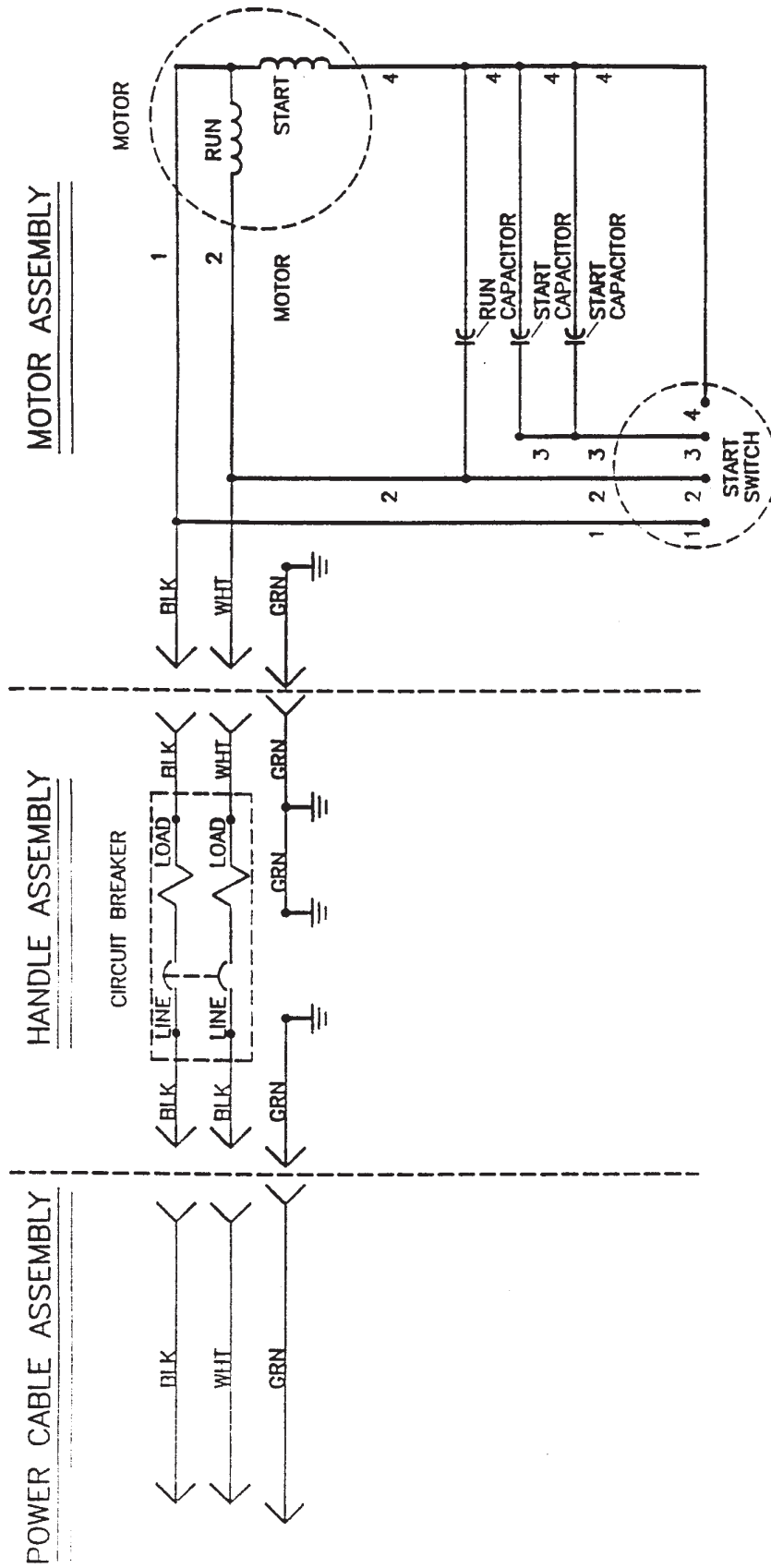

**Clarke**  
**American Sanders**  
Model American 8 Floor Sander  
Drawing #1 Handle Assembly 12/00

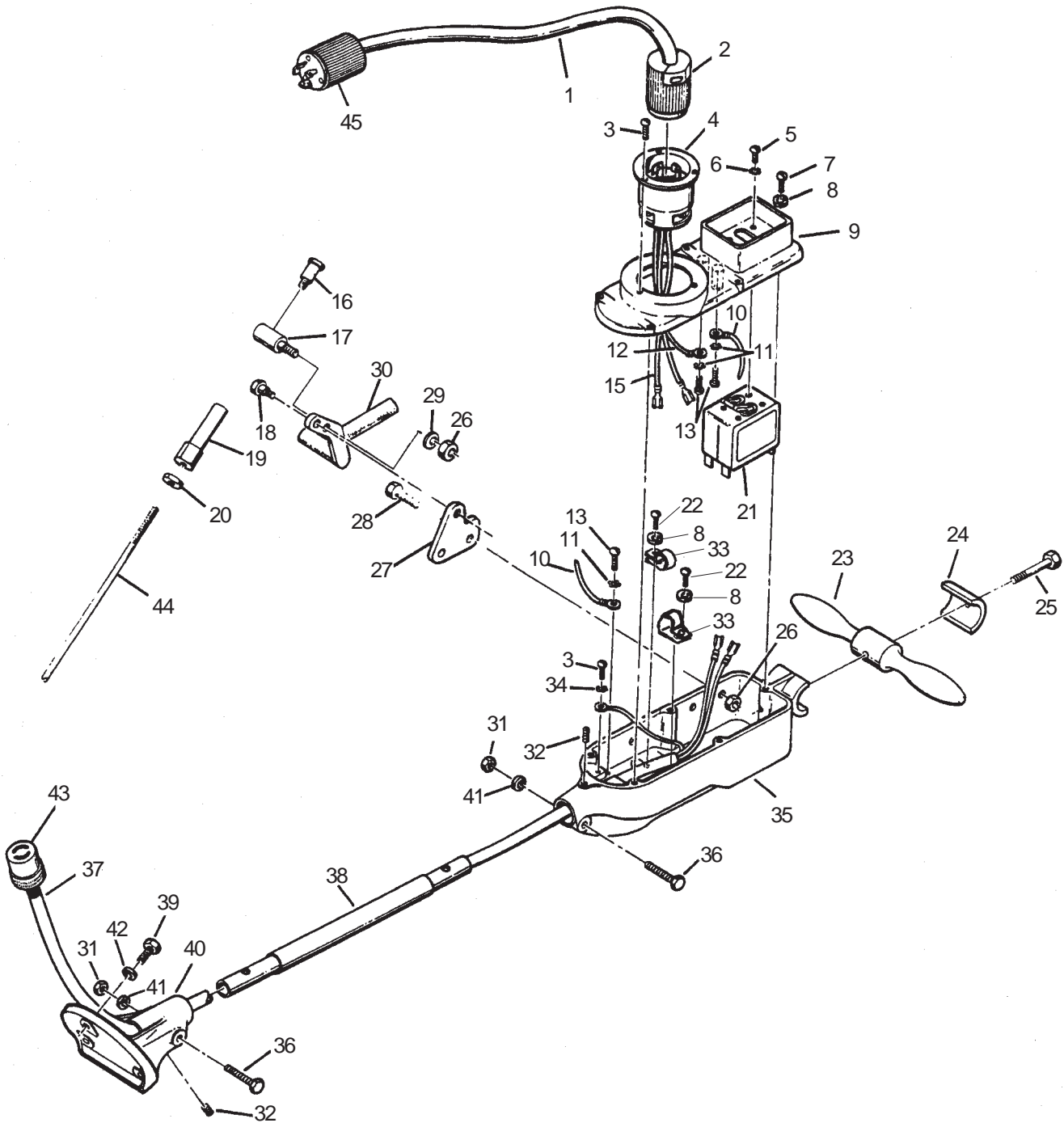

**Clarke®**  
**American Sanders**  
**Model American 8 Floor Sander**  
**Parts List #1 Handle Assembly 12/00**

Ref No.	Part No	Description	Qty
1	ref.	Cord Set	1
2	41706A	Connector	1
3	962065	Screw - 8-32 x ¼ Pn St Mach	4
4	43501A	Inlet - 20A, 250V	1
5	962070	Screw - 6-32 x ¼ Pn St Mach	4
6	980607	Washer - #1106 Shakeproof	4
7	962794	Screw - 10-24 x 1	5
8	980650	Washer - ¾ Lock	7
9	22127C	Cover - Switch Housing	1
10	48901A	Wire Ass'y - Green	1
11	980699	Washer - #1210 Shakeproof	3
12	48900A	Wire Assembly Ground	1
13	85393A	Screw - 10-24 x ¼ Pn St Mach	3
14			
15	49023A	Wire Ass'y - Black	2
16	80021A	Bolt ¾ x 5/8	6
17	66151A	Pivot Control Rod	1
18	80022A	Bolt , Shoulder ½ x 5/8	1
19	67129A	Adjuster, Control Rod	2
20	920148	Nut ¾ - 16	1
21	41411A	Switch - Circuit Breaker	1
22	85517A	Screw - 10-24x½	2
23	64405A	Handle - Steering	1
24	21904C	Clamp	1
25	85818A	Screw 5/16 -18x 2½ Hex St	1
26	920284	Nut ¼-20	2
27	66694A	Plate, Control Lever	1
28	85393A	Screw ¼-2 x 1¼	2
29	980646	Washer ¼	1
30	25602A	Lever, Control	1
31	920256	Nut - 5/16-18 Hex	3
32	86200A	Screw ¾ -16 x 5/8 St St Dogpt	2
33	51074A	Clamp - Cord	2
34	980621	Washer - .1681 x .3700 SH 1108	1
35	20704C	Housing - Switch	1
36	85816A	Screw - 5/16 -18x1¾	2
37	41917A	Cord - Interconnecting	1
38	66116C	Pipe - Handle	1
39	962288	Screw - ¾-16 X 1" Hex St Mach	3
40	21105C	Mount - Handle	1
41	980652	Washer -.319 x .586 x .078 St Lk	2
42	980638	Washer - ¾ Lt Spring Type	3
43	41707A	Connector	1
44	67143A	Rod Control	1
45	45608A	Plug	1

**Clarke**  
**American Sanders**  
**Model American 8 Floor Sander**  
**Drawing #2 12/00**

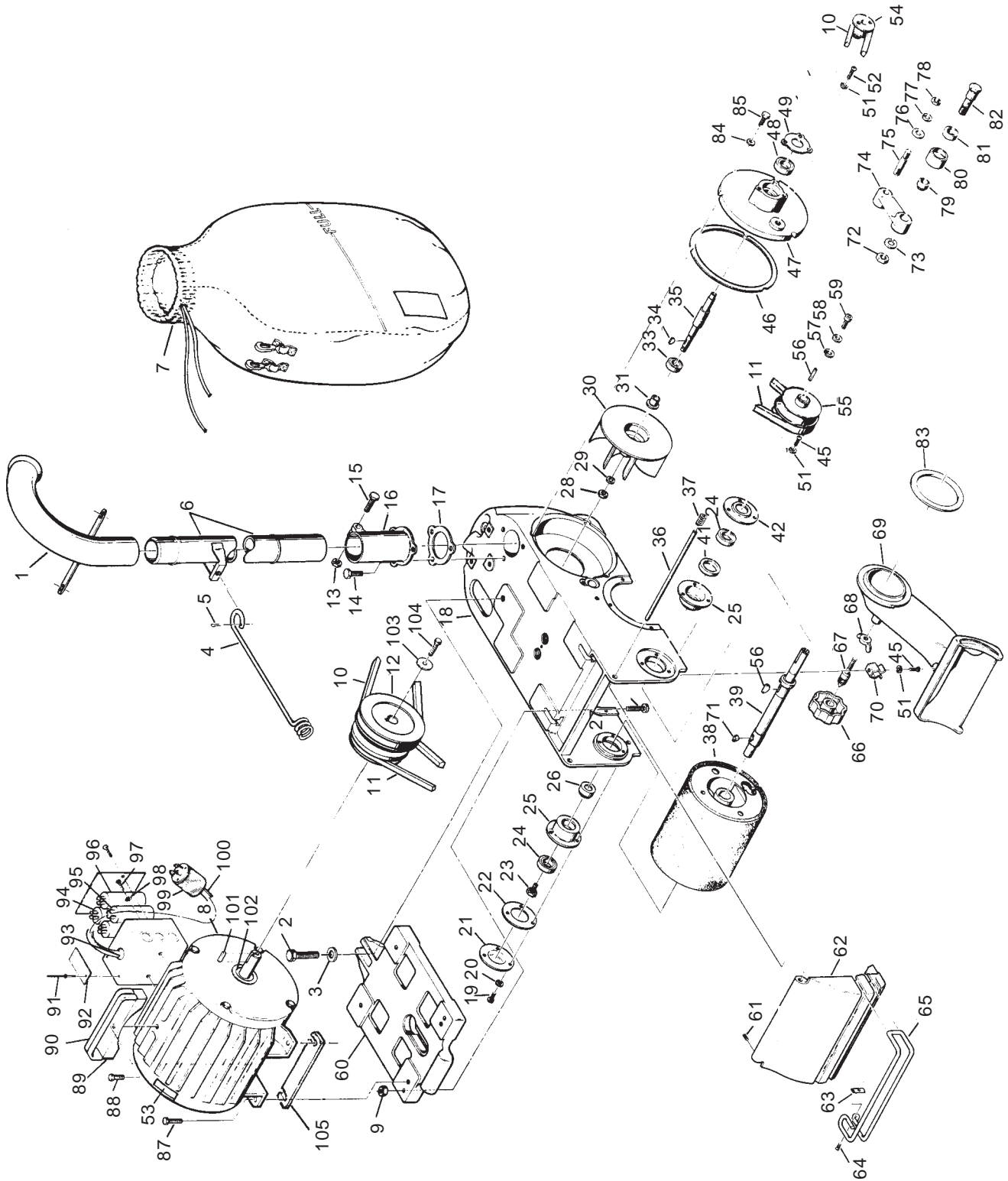

**Clarke**  
**American Sanders**  
**Model American 8 Floor Sander**  
**Parts List #2 12/00**

Ref #	Part No.	Description	Qty
1	62800A	Pipe - Ass'y	1
2	85706A	Screw - 1/2 - 13 x 1 3/4 Hex St	1
3	87006A	Washer - .56 X 1.38 X .11 Flat	1
4	60401A	Arm - Cable	1
5	925036	Pin - Cotter	1
6	66110A	Pipe Ass'y	1
7	50954A	Dust - Bag	1
8	44639A	Motor 230/60	1
	44640A	Motor 240/50	1
9	920260	Nut - 3/8-16 x 5/16 Hex	2
10	50920A	Belt - V	1
11	51024A	Belt - V	1
12	66168A	Pulley - Motor	1
13	920256	Nut 5/16 - 18 Hex	1
14	85820A	Screw - 3/8-16 x 5/8 Hex St Cap	3
15	85816A	Screw - 5/16-18 x 1 3/4 Hex St Flt	1
16	27801C	Support - Dust Pipe	1
17	34223A	Gasket - Pipe Support	1
18	23405B	Frame - Main	1
19	962016	Screw - 10-24 x 1/2 Pn St Mach	3
20	980650	Washer - 1941 x 3230 x 040 Lk	3
21	62608C	Cover - Housing Drum	1
22	54305A	Gasket	1
23	67316A	Screw - Drum Lock	1
24	51110A	Bearing - Ball	2
25	64703A	Housing - Bearing Shaft	2
26	67811A	Spacer - Drum	1
27	69032A	Screw - Motor Locating	2
28	81202A	Nut - 7/16-14 Hex L.H.	1
29	87002A	Washer - .47 x .94 x .06 Flat St	1
30	23301A	Fan	1
31	61602A	Collar	1
33	902567	Bearing Ball	1
34	65302A	Key - 1/8 x 1/2 #3 Woodruff	1
35	67411A	Shaft - Fan	1
36	67414A	Shaft - Drum Cover	1
37	67911A	Spring	1
38	13501A	Drum - RM	1
39	67425A	Shaft Drum	1
NI	18601A	Shaft Ass'y Drum includes 56, 39, 71	(1)
41	67313A	Spacer - Drum Bearing	1
42	66918A	Retainer - Bearing	1
45	962983	Screw - 1/4-20 x 5/8 Pn St Mach	4
46	34225A	Gasket - Plate Support	1
47	26503C	Plate Support - Fan	1
48	51111A	Bearing Ball	1
49	62001A	Cap - Bearing	1
50 *	38109A	Seal Dust Pipe	1
51	980657	Washer - 17/64 I x 31/64 O x 1/16	7
52	962823	Screw - 1/4 - 20 x 1/2 Pn St Mach	3
53	77234A	Label, Lifting Warning	1

Ref #	Part No.	Description	Qty
54	66169A	Pulley - Fan Shaft	1
55	66167A	Pulley - Drum	1
56	80501A	Key - 5/16 Sq. x 1.25	2
57	68703A	Washer - Drum Pulley	1
58	980652	Washer - .319 x .586 x .078	1
59	962258	Screw - 5/16-18 x 1" Soc Cap	1
60	26107C	Platform Motor	1
61	962262	Screw - 8-32 x 1/4 St St Cup Pt	1
62	22101A	Cover - Drum	1
63	62404A	Clamp - Bumper Rear	1
64	962348	Screw - 10-24 x 1/2 Flat St Cap	1
65	31210A	Bumper - Drum Cover	1
66	26900A	Ring - Lock-Pan-Dust	1
67	67311A	Screw	1
68	81900A	Nut - 7/16 - 14 Hex St	1
69	26100A	Pan - Dust	1
70	61600A	Clip - Dust	1
71	65301A	Key #606	1
72	920280	Nut - 5/8 - 18 x 3/8 Hex Jam	1
73	87102A	Washer - .62 x 1.09 x .16	1
74	20400B	Arm Idler	1
75	68000A	Stud - Idler	1
76	87005A	Washer - .52 x 1.00 x 1.00	1
77	87101A	Washer - .50 X .12 Lock St	1
78	920132	Nut - 1/2-20 Hex Jam	1
79	67813A	Spacer - Idler Bearing	1
80	67701A	Sleeve - Idler	1
81	902550	Bearing	1
82	67317A	Shaft - Idler	1
83	34222A	Gasket - Pan Dust	1
84	980651	Washer-11/32 x 11/160 X 1/16	3
85	85811A	Screw - 3/8-18 x 3/4	3
86	962103	Screw - 5/16-18 x 3/8	2
87	962216	Screw - 3/8-16 x 1/4	4
88	962870	Screw - 3/8-16 x 1	1
89	64460A	Handle Motor	1
90	32357A	Cover Handle	2
91	930087	Rivet	2
92	74044A	Plate Safety	1
93	697502	Strain Relief	1
94	41305A	Capacitor Start	2
95	41304A	Capacitor Run	1
96	47378A	Switch Start	1
97	962823	Screw - 1/4-20 x 1/2	2
98	980614	Washer	2
99	45604A	Plug Locking	1
100	41945A	Cord Motor	1
101	915098	Key 1/4-52 x 1 1/2	1
102	57712A	Ring Retaining	1
103	87034A	Retainer Pulley	1
104	962288	Screw 3/8-16 x 1	1
105	67642A	Shim, Motor	4

\*NOTE: #50 not illustrated.

**Motor Parts Not Illustrated**

Part #	Description	Qty.
50563A	End Bell	1
52768A	Front Cover	1
53998A	Fan	1
52769A	Fan Cover	1

Part #	Description	Qty.
51188A	Bearing Front	1
902547	Bearing Rear	1
40316A	Armature Assembly	1

**Clarke®**  
**American Sanders**  
**American 8 Floor Sander**  
**Assembly Drawing #3 5/03**

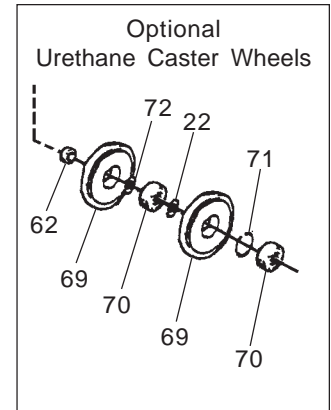
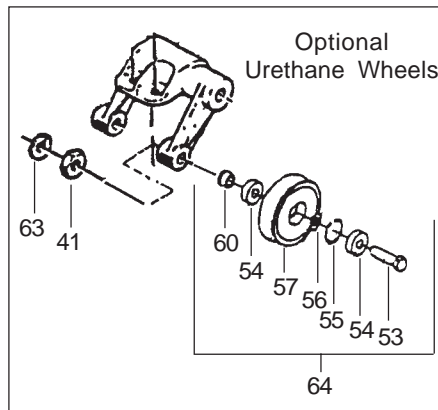
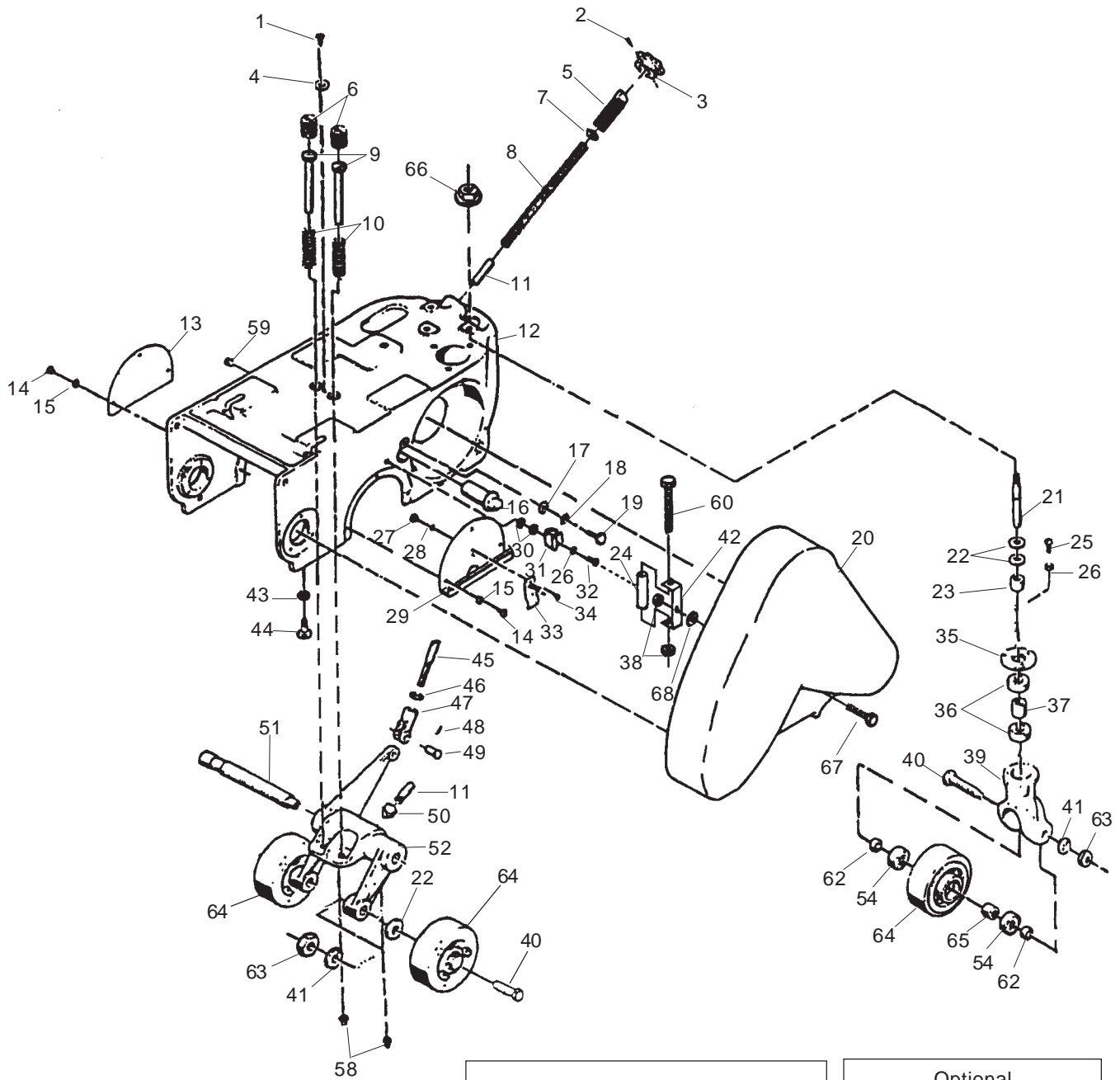



**Clarke®**  
**American Sanders**  
**American 8 Floor Sander**  
**Assembly Parts List #3 5/03**

07032C  
07048C  
07105A  
07106A

Ref. No	Part No.	Description	Qty	Qty
1	962052	Screw - 10-24 x 1/2 Flt St Mach	1	1
2	962161	Screw - 10-24 x 3/8 St St Cuppt	2	2
3	25200C	Knob - Hand	1	1
4	66912A	Retainer, Screw Adjusting	1	1
5	67309A	Screw	1	1
6	67312A	Screw	2	2
7	87000A	Washer	1	1
8	67905A	Spring	1	1
9	66123A	Plunger, Spring	2	2
10	67906A	Spring	2	2
11	67107A	Rod - Pivot	1	1
12	23405B	Frame, Main	1	1
13	66628C	Plate, Cover Wheel	1	1
14	962015	Screw, 10-24 x 3/8 Pn St Mach	6	6
15	980650	Washer, Lock	6	6
16	62801A	Eccentric	1	1
17	87007A	Washer, Control Shaft Eccentric	1	1
18	980614	Washer, #1114 Shakeproof	1	1
19	85700A	Screw, 1/4-20 x 1" Hex	1	1
20	70224B	Kit Guard, Belt	1	1
21	60715B	Bolt, Pivot	1	1
22◆	87003A	Washer, .59 x 1.00 x .09 Flat	4	3
23	67812A	Spacer, Bracket	1	1
24	51069A	Tube, Latch	1	1
25	962823	Screw, 1/4-20 x 1/2 Pn St Mach	3	3
26	980657	Washer, 17/64 I x 31/64 O x 1/16	4	4
27	920112	Nut, #6-32 Hex	2	2
28	980607	Washer, #1106 Shakeproof	2	2
29	66627A	Cover, Truck Wheel	1	1
30	87004A	Washer, Fit St	2	2
31	61600A	Clip, Dust	1	1
32	962983	Screw, 1/4-20 x 5/8 Pn St Mach	1	1
33	63904A	Clamp, Belt Guard	1	1
34	85313C	Screw, 6-32 x 3/8 Pn St Mach	2	2
35	66913A	Retainer, Bearing	1	1
36	51112A	Bearing, Ball	2	2
37	67821A	Spacer	1	1
38	81102A	Nut, 1/4-20 ESNA	2	2
39	29403C	Yoke, Wheel	1	1
40	60101A	Axle	3	1
41	87101A	Washer	3	3
42	51071A	Bracket, Latch	1	1
43	920160	Nut 5/16 -18	1	1
44	86201A	Screw 5/16 -18 x 1"	1	1
45	67143A	Rod, Control	1	1
46	920260	Nut 3/8 -16 x 5/16	1	1
47	53917B	Clevis, Control Rod	1	1
48	925036	Pin, Cotter 3/32 x 3/4	1	1
49	66503A	Pin, Fork	1	1
50	62000A	Nut, End	1	1
51	67412A	Shaft, Control	1	1
52	21101A	Bracket, Truck Wheel	1	1
53	60547A	Axle	-	2
54	51225A	Bearing, Ball	6	6
55	167312	Ring, Retainer	-	2
56	60481A	Spacer	-	2
57	50992A	Wheel, Asm.	-	2
58	54000A	Fitting, Lub	2	2
59	57101A	Plug, Soft	1	1
60	60544A	Spacer	2	2
62	67810A	Spacer	2	2
63	920196	Nut, 1/2 - 13	3	3
64	59928A	Wheel (Steel)	3	-
	10243A	Klt, Wheel (Urethane)(Optional)	-	-
65	67817A	Spacer	1	-
66	81209A	Nut, 1/2-13 Flange	1	1
67	85806A	Screw, 1/4-20 x 3/4	1	1
68	87007A	Washer, 1/4- 3/4 x .06	1	1
69◆	61333A	Wheel, Caster 4"	-	2
70◆	51226A	Bearing	-	4
71◆	747304	Ring, Retaining	-	2
72◆	61355A	Spacer	-	2

NOTE: ◆ indicates a change has been made since the last publication of this manual.

**Clarke**  
**American Sanders**  
 American 8 Floor Sander  
 Accessories Drawing & Parts List #4 12/00

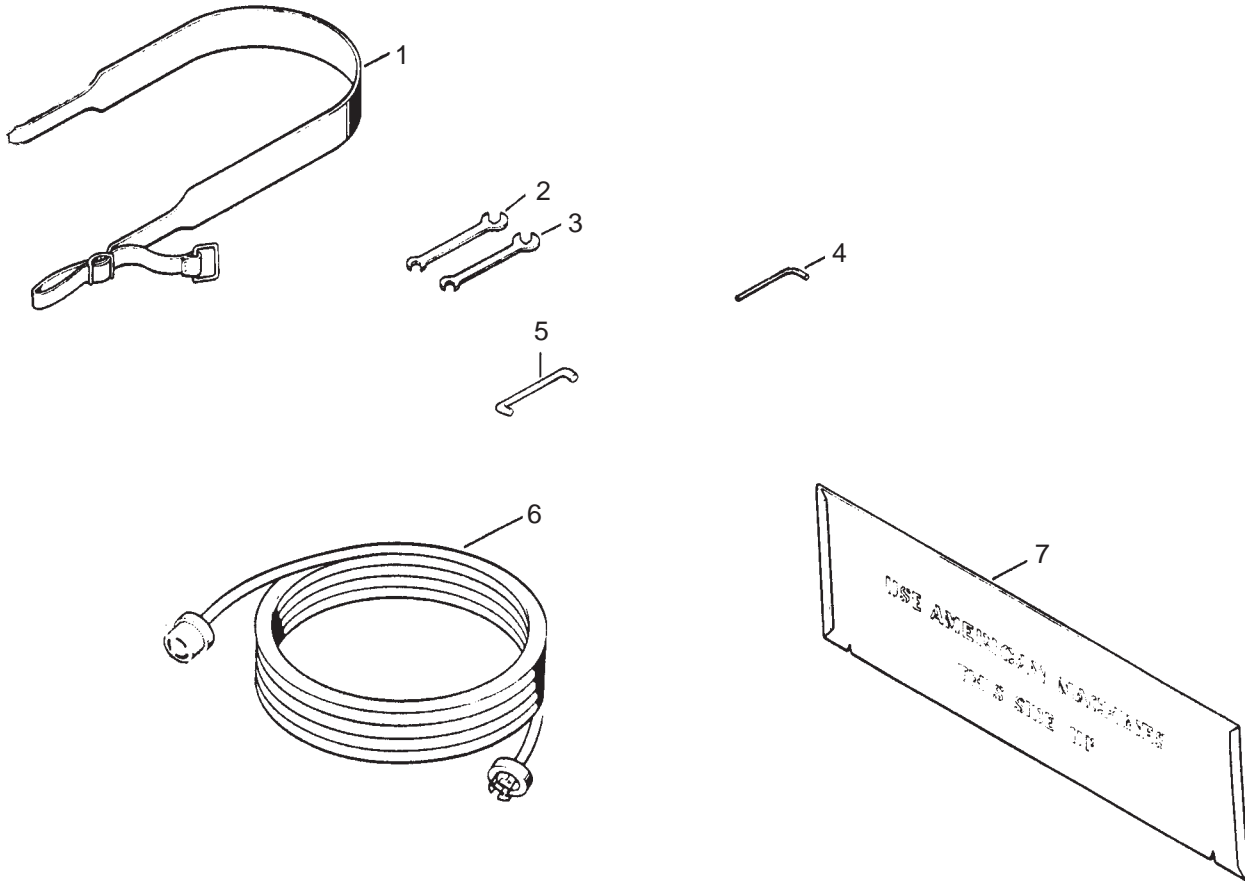

Ref. #	Part No.	Description	Qty
1	60724A	Belt, Operating	1
2	59811A	Wrench, End $\frac{3}{4} \times \frac{7}{16}$	1
3	59810A	Wrench, End $\frac{9}{16} \times \frac{7}{16}$	2
4	59815A	Wrench $\frac{5}{32}$	1
5	64415A	Handle, Carrying	1
6	42201A	Cord Set 230V 60Hz	1
	40010A	Cable Australia	1
7	68315A	Template	1

## Chatter - Wave Prevention

Clarke American Sanders are designed and manufactured to the most rigid tolerances. However, after a finishing cut it is possible to see "chatter" or "waves".

The best guarantee to remove the chatter is to finish the floor with a rotating horizontal sander, such as Clarke American Sanders's Sander 16.

To minimize chatter when using a belt or drum sander the following steps should be taken:

- 1) DRUM PAPER...insure the paper is secured in the slot, but not too tight. Paper that is too tight will force the drum slot wider, leaving a "slot mark chatter" on the floor.

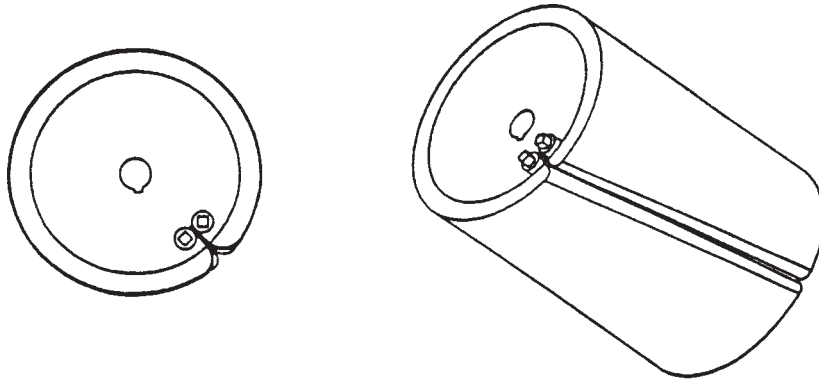

- 2) DRUM MARKS.....are caused by the operator lowering the drum to the floor without forward traverse. These marks should be removed by cutting at a 45 degree angle to the mark. Cutting at the mark while maintaining the same path will only increase the mark depth and width.

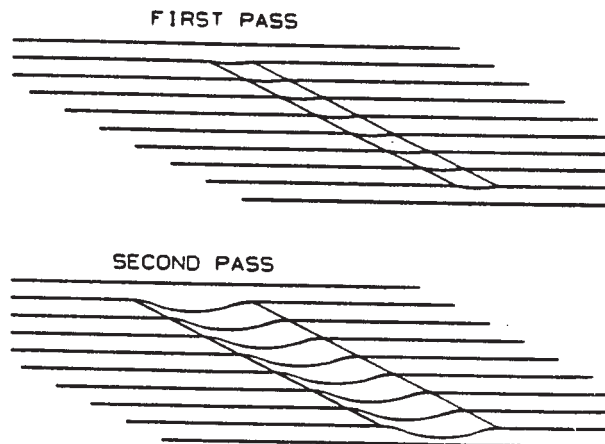

### Chatter Wave Prevention (cont)

- 3) UNEVEN WALKING PACE..... can leave lengthy “waves”. The machine cuts more material during the slower pace. Pay particular attention to a steady, even pace.
- 4) EXCESSIVE LIGHT CUTS.... may reveal high spots on the paper/contact wheel and cause chatter. Take a heavier cut and increase the pace.
- 5) DEBRIS.... lodged between the paper and the drum will leave chatter. On a belt sander, debris may be adhered to the drum. Insure the drum is clean and free of debris before placing the paper on.
- 6) SANDER PAPER QUALITY....may vary. Belt seams can be thicker on low quality paper and cause chatter. Use only Clarke American Sanders specified sandpaper.

### PROPER CARE OF YOUR MACHINE CAN MINIMIZE CHATTER AND WAVES.

- 1) V-BELTS.... can cause vibration and chatter if they are of low quality. Use only belts specified by Clarke American Sanders.
- 2) TRUCK AND CASTER WHEELS....with flat spots, out-of-roundness, or debris adhered to their surface can cause “waves” or a “chatter effect”. Always clean and inspect all wheels before starting to sand, and before the finish cut. Replace or true the wheels if found to be out-of-round.
- 3) DUST PICK-UP SHOES.....may need adjusted differently for different materials that are to be sanded. An improperly adjusted shoe will leave trailing debris that will be run over by the wheels and cause “random waves”.
- 4) CONTACT WHEELS (DRUMS).....may be out-of-round and cause “chatter”. Contact your Clarke American Sanders dealer for assistance to true or replace the drum.
- 5) BEARINGS.....in the motor, drum, or fan system may become worn and induce vibration which could cause “chatter”.
- 6) PULLEYS.....that are damaged or severely worn can induce vibration and cause “chatter”. Contact your Clarke American Sanders dealer for assistance.

**Clarke American Sanders is not responsible for rework of floors that are unacceptable to the customer. It is your responsibility to insure your equipment is in proper operating order, and that you use the right machine for the job.**

# CLARKE PRODUCT SUPPORT BRANCHES

## U. S. A. Locations

### PRODUCTION FACILITIES

**Clarke®**, Springdale, Arkansas  
2100 Highway 265  
Springdale, Arkansas 72764  
(479) 750-1000

**Customer Service - 1-800-253-0367**

**Technical Service - 1-800-356-7274**

**American Lincoln®**, Bowling Green, Ohio 43402  
1100 Haskins Road

### SERVICE FACILITIES

**Clarke®**, Elk Grove, Illinois 60007  
2280 Elmhurst Road  
(847) 956-7900

**Clarke®**, Denver, Colorado 80204  
1955 West 13th Ave.  
(303) 623-4367

**Clarke®**, Houston, Texas 77040  
7215 North Gessner Road  
713-937-7717

### SERVICE AND SALES FACILITY

**American Lincoln® / Clarke**, Madison Heights,  
Michigan 48071-0158  
29815 John R.  
(810) 544-6300

**American Lincoln® / Clarke**, Marietta, Georgia 30066  
1455 Canton Road  
(770) 973-5225

---

**Clarke®**

**Clarke American Sanders**

**A.L. Cook**

**Customer Service Headquarters and Factory**

2100 Highway 265  
Springdale, Arkansas 72764  
(479) 750-1000

**Technical Service**

1-800-356-7274

## European Locations

### PRODUCTION FACILITIES

ALTO Danmark A/S, Aalborg  
Blytaekkervej 2  
DK-9000 Aalborg  
+45 72 18 21 00

ALTO Danmark A/S, Hadsund  
Industrikvarteret  
DK-9560 Hadsund  
+45 72 18 21 00

### SALES SUBSIDIARIES

ALTO US - Canada, Ontario (Canada)  
4080 B Sladeview Crescent Unit 1  
Mississauga, Ontario L5L 5Y5  
(905) 569 0266

ALTO Overseas Inc., Sydney (Australia)  
1B/8 Resolution Drive  
Caringbah NSW 2229  
+61 2 9524 6122

ALTO Cleaning Systems Asia Pte Ltd., Singapore  
No. 17 Link Road  
Singapore 619034  
+65 268 1006

ALTO Deutschland GmbH, Bellenberg (Germany)  
Guido-Oberdorfer-Straße 2-8  
89287 Bellenberg  
+49 0180 5 37 37 37

ALTO Cleaning Systems (UK) Ltd., Penrith  
Gilwilly Industrial Estate  
Penrith  
Cumbria CA11 9BN  
+44 1768 868 995

ALTO France S.A. Strasbourg  
B.P. 44, 4 Place d'Ostwald  
F-67036 Strasbourg  
Cedex 2  
+33 3 8828 8400

ALTO Nederland B.V.  
Postbus 65  
3370 AB Hardinxveld-Giessendam  
The Netherlands  
+31 184 677 200

ALTO Sverige AB, Molndal (Sweden)  
Aminogatan 18  
Box 4029  
S-431 04 Molndal  
+46 31 706 73 00

ALTO Norge A/S, Oslo (Norway)  
Bjornerudveien 24  
N-1266  
+47 2275 1770

## **Clarke® American Sanders U. S. Warranty**

This Clarke American Sanders Industrial/Commercial Product is warranted to be free from defects in materials and workmanship under normal use and service for a period of one year from the date of purchase, when operated and maintained in accordance with Clarke American Sanders's Maintenance and Operations Instructions.

This warranty is extended only to the original purchaser for use of the product. It does not cover normal wear parts such as electrical cable or V-belts.

If difficulty develops with the product, you should:

- (a). Contact the nearest authorized Clarke American Sanders repair location or contact Clarke American Sanders Service Operations Department, 2100 Highway 265, Springdale, Arkansas 72764, for the nearest authorized Clarke American Sanders repair location. Only these locations are authorized to make repairs to the product under this warranty.
- (b). Return the product to the nearest Clarke American Sanders repair location. Transportation charges to and from the repair location must be prepaid by the purchaser.
- (c). Clarke American Sanders will repair the product and or replace any defective parts without charge within a reasonable time after receipt of the product.

Clarke American Sanders's liability under this warranty is limited to repair of the product and/or replacement of parts and is given to purchaser in lieu of all other remedies, including INCIDENTAL AND CONSEQUENTIAL DAMAGES.

THERE ARE NO EXPRESS WARRANTIES OTHER THAN THOSE SPECIFIED HEREIN. THERE ARE NO WARRANTIES WHICH EXTEND BEYOND THE DESCRIPTION OF THE FACE HEREOF. NO WARRANTIES, INCLUDING BUT NOT LIMITED TO WARRANTY OF MERCHANTABILITY, SHALL BE IMPLIED. A warranty registration card is provided with your Clarke American Sanders product. Return the card to assist CLARKE AMERICAN SANDERS in providing the performance you expect from your new floor machine.

Clarke, 2100 Highway 265, Springdale, Arkansas 72764.

**Clarke American Sanders reserves the right to make changes or improvements to its machine without notice.**

**Always use genuine Clarke American Sanders Parts for repair.**

**Clarke®**  

---

**American Sanders**

2100 Highway 265  
Springdale, Arkansas, 72764